



BASIC PUMP FUNDAMENTALS

When selecting centrifugal pumps

Brief History of KSB International

- 1871 KSB founded in Frankenthal, Germany by Klein, Schanzlin & Becker
- 1940 Operations in Argentina, Pakistan, Brazil, India
- 1980 Operations in France, Shanghai, USA
- 1991 Acquisition of Ajax (& Forrers) Pumps Australia

Major manufacturing plants in Germany, Italy, France, Netherlands, India, Pakistan, China, Brazil, USA, Mexico, Canada, Indonesia, South Africa

Brief History of KSB in Australia

- 1939 Ajax Pumps Works established in Melbourne Victoria
- 1948 Ajax Pumps foundry opened in Kyneton, rural Victoria
- 1962 Forrers Pump Works Ipswich Qld begins producing submersible sewage pumps
- 1988 Ajax Pumps acquires the Forrers Pump Company in Ipswich Queensland
- 1991 KSB AG acquires Ajax Pumps, establishing KSB Ajax Pumps Pty Ltd
- 2007 Change name to KSB Australia
- 2011 Open new facility in Bundamba, QLD
- 2015 Open new facility in Hope Valley, WA

79 years in Australia and 147 years in Germany





BASIC PUMP FUNDAMENTALS

When selecting centrifugal pumps

Our Service and Sales facilities in QLD and WA





BASIC PUMP FUNDAMENTALS

When selecting centrifugal pumps

Discover the world of KSB



- KSB Australia is the local subsidiary of Germany's number one pump manufacturer, KSB AG.
- We provide first-class products, excellent service and efficient, reliable solutions to the challenges of fluid transport.

[Company Film KSB Group.mp4](#)

MINING

WATER

WASTE WATER

ENERGY

BUILDING SERVICES

INDUSTRY





BASIC PUMP FUNDAMENTALS

When selecting centrifugal pumps

We will be talking about the basic criteria to keep in mind when selecting centrifugal pumps



BASIC PUMP FUNDAMENTALS

When selecting centrifugal pumps

When Selecting Pumps we **must** know:

- What we are pumping i.e. chemically aggressive, solids content etc.
- What is the temperature
- Is there any abrasive content
- What is the specific gravity
- The viscosity
- Required flow rate
- Total pump head



BASIC PUMP FUNDAMENTALS

When selecting centrifugal pumps

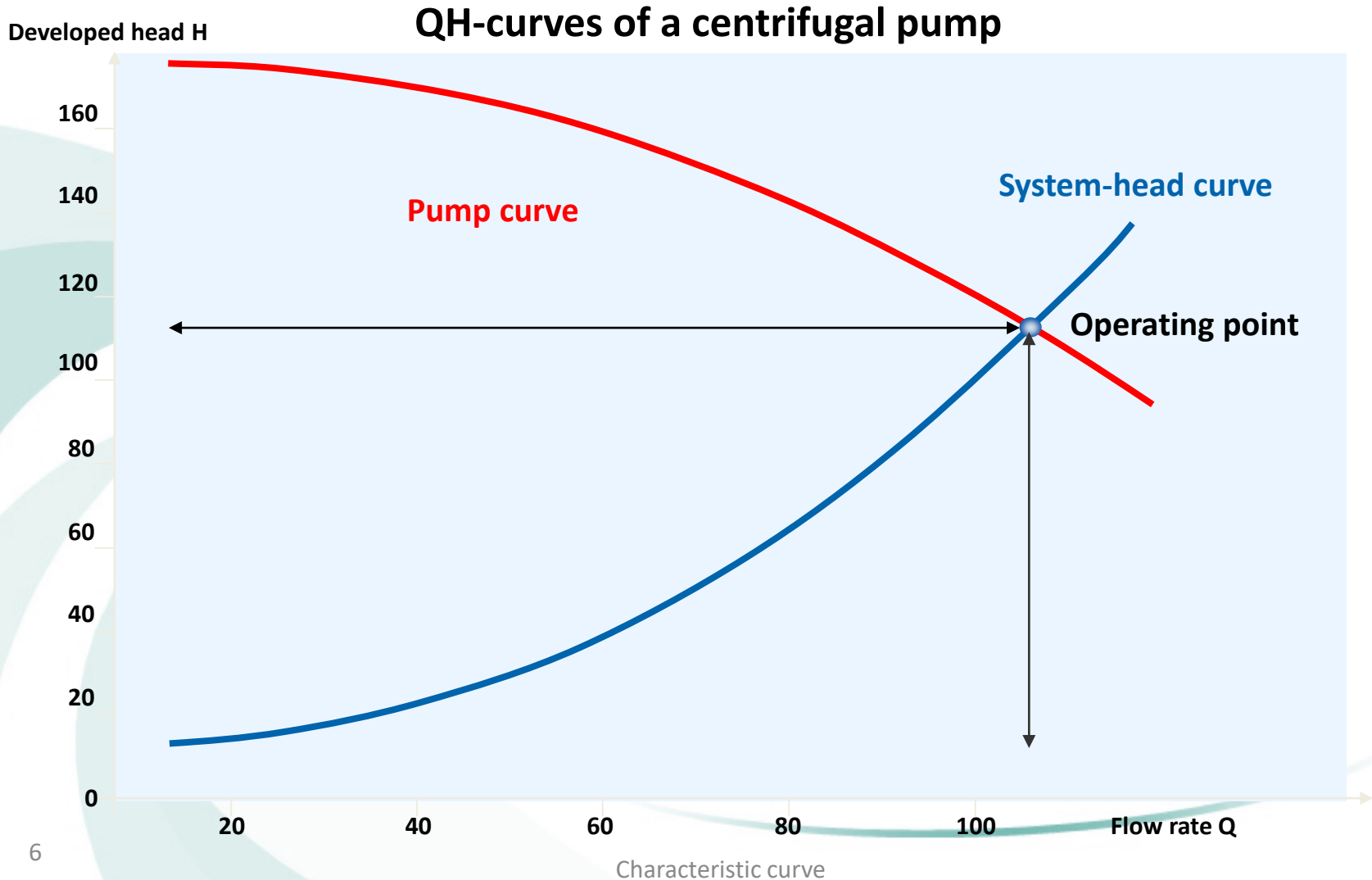



BASIC PUMP FUNDAMENTALS

When selecting centrifugal pumps

Pump Duty:

Flow Rate (Q)

- The units typically used are m^3/h , m^3/s , l/s , l/h
- The flow rate of a centrifugal pump is independent of the **density** of the fluid being pumped
- The **viscosity** of the fluid being pumped affects the flow rate of the pump. The higher the viscosity, the lower the flow and the lower the viscosity the higher the flow
- Viscosity will change with temperature
- This will affect the power consumption of your pump
- 40 Centipoise is considered viscous



BASIC PUMP FUNDAMENTALS

When selecting centrifugal pumps

Pump Duty:

Head (H) or (TDH)

- The unit is specified in meters head
- A centrifugal pump will deliver the same head to various fluids independent of its density
- If the viscosity of a fluid changes the developed head will also change

BASIC PUMP FUNDAMENTALS

When selecting centrifugal pumps

Pressure and developed head

$$H = \frac{p}{\rho \cdot g}$$

wobei:

H gleich Förderhöhe in [m]

p gleich Druck in [Pa = N/m²]

ρ gleich Flüssigkeitsdichte in [kg/m³]

g gleich Erdbeschleunigung in [m/s²]

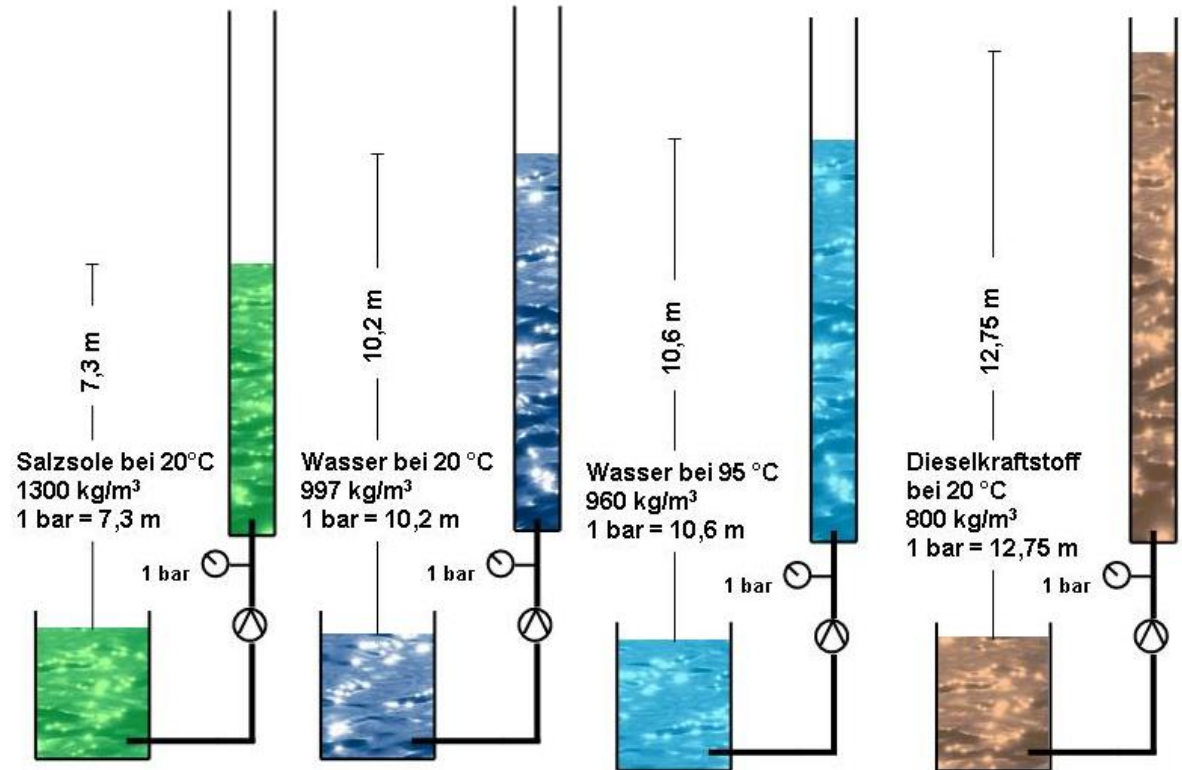



BASIC PUMP FUNDAMENTALS

When selecting centrifugal pumps

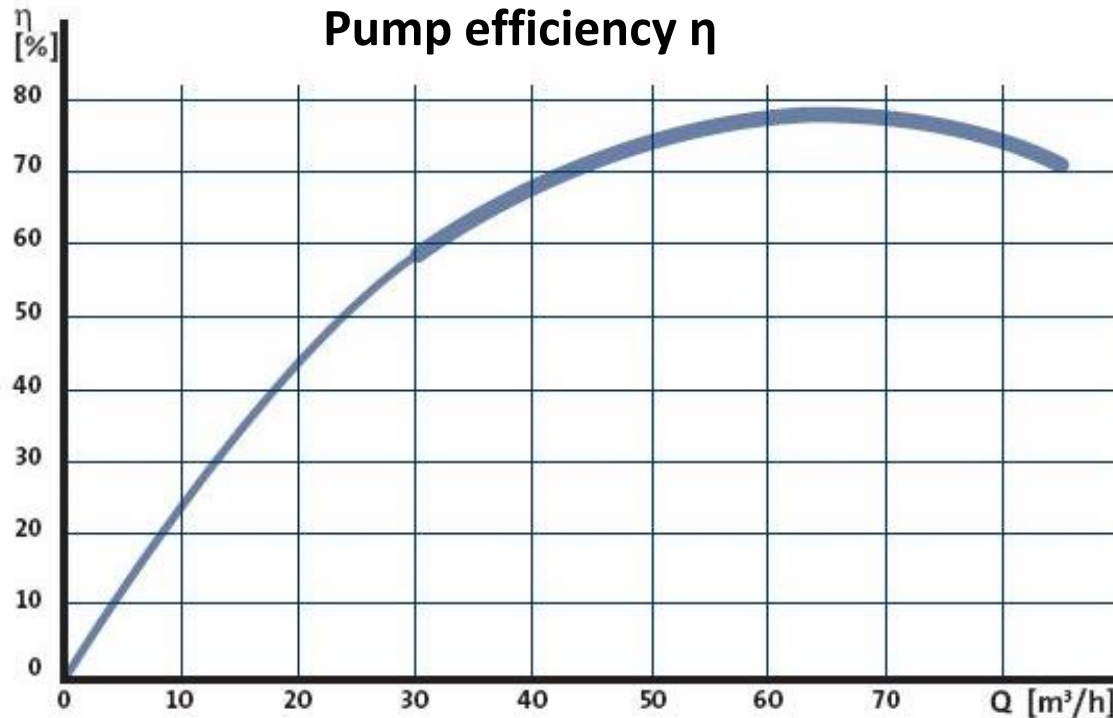

Q_{opt} is the point with the **best efficiency** of the pump, also common as **BEP** (= best efficiency point).

The **pump efficiency η** shows the proportion between the **flow rate P_h** of a pump and the **mechanical power P_2** of a pump shaft:

$$\eta = \frac{P_h}{P_2} = \frac{\rho \times Q \times g \times H}{P_2}$$

(ρ in kg/dm^3 , Q in m^3/s ,
 $g = 9,81 \text{ m}^2/\text{s}$, H in m , P in kW)



BASIC PUMP FUNDAMENTALS

When selecting centrifugal pumps

Optimal operating range of a centrifugal pump

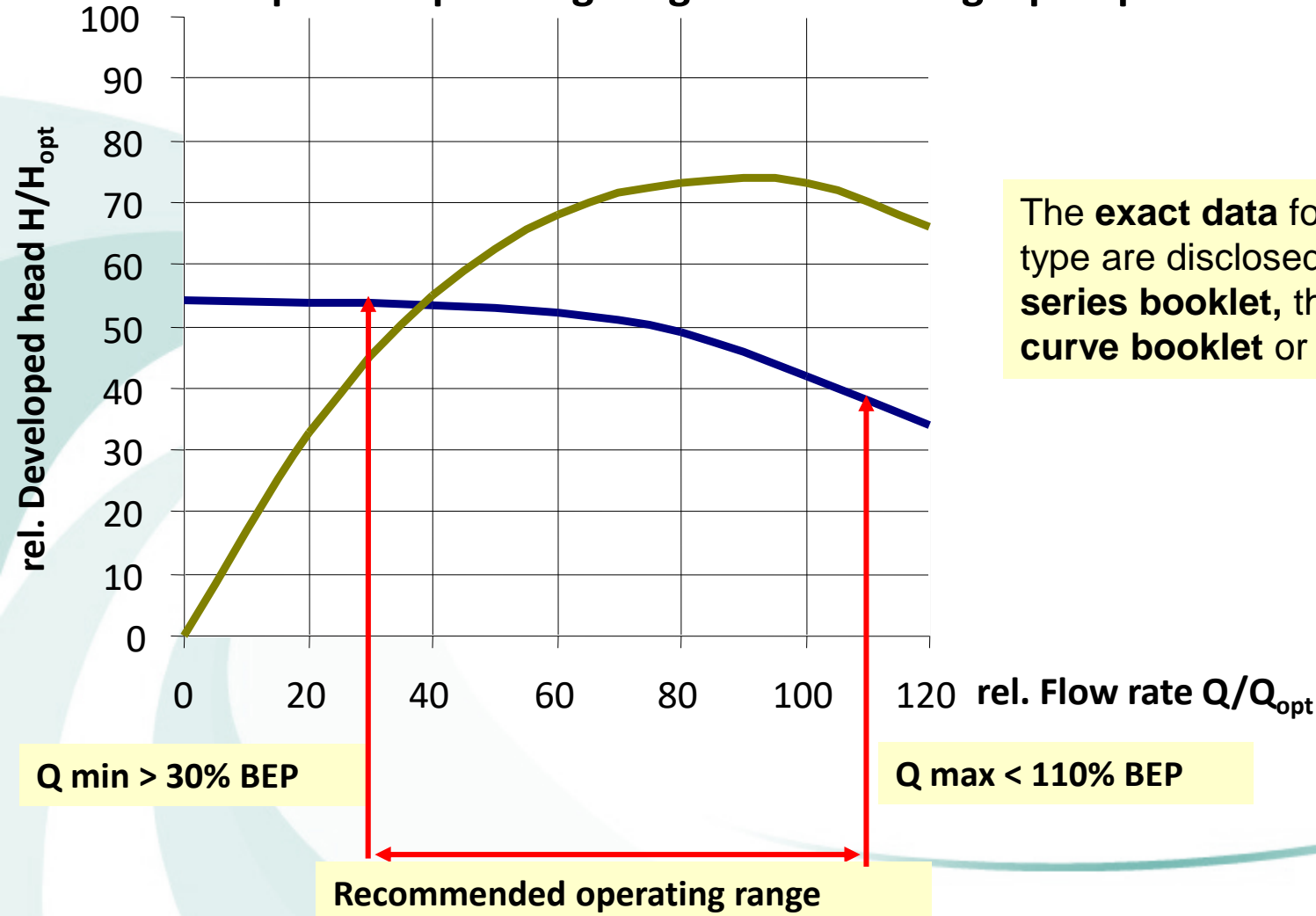

The **exact data** for each pump type are disclosed in the **type series booklet**, the **characteristic curve booklet** or in **EasySelect**.

Q min > 30% BEP

Q max < 110% BEP

Recommended operating range



BASIC PUMP FUNDAMENTALS

When selecting centrifugal pumps

Minimum flow rate

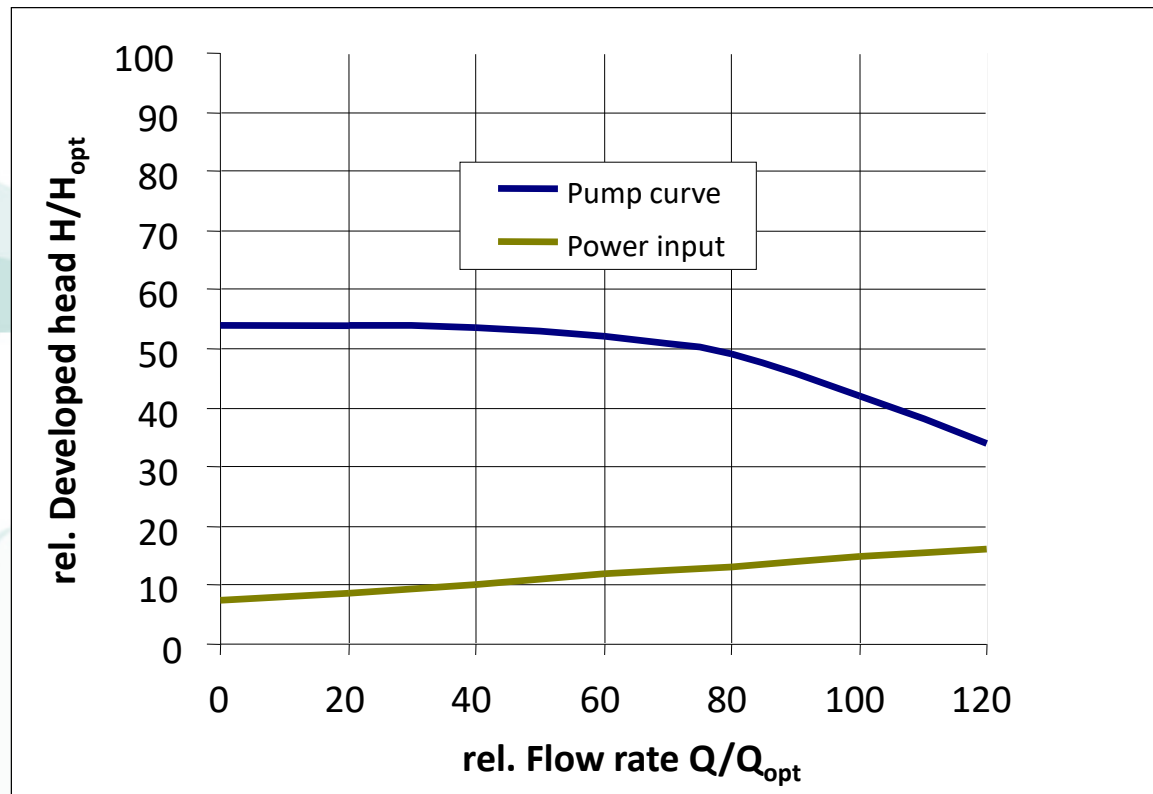

Why minimum flow rate? → protection of the pump against heating and unstable flow ratios (noise, vibrations etc.)

The minimum flow rate of a centrifugal pump is ca. 15% of the Q_{opt}

The exact data of each pump type is disclosed in the type series booklet or in EasySelect

BASIC PUMP FUNDAMENTALS

When selecting centrifugal pumps

Characteristic curve of the power input P_2

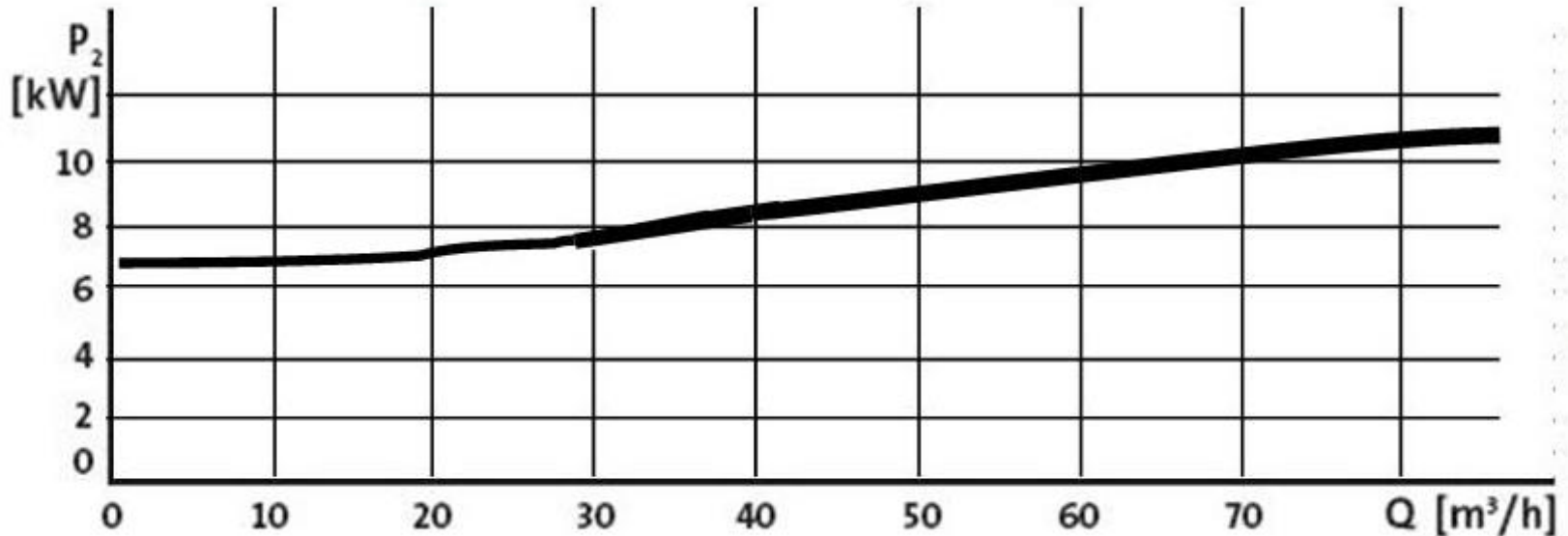

The **P_2 characteristic curve** shows the proportion between the mechanical power input of a centrifugal pump and the flow rate Q . If Q rises, P_2 rises also.

Important: The characteristic curve shows the mechanical power input P_2 . Electrical power input of the motor **$P_1 = P_2 / \eta_{mot}$** (motor efficiency)

The P_2 characteristic curve shows the power input of a stage at **multistage pumps!**



BASIC PUMP FUNDAMENTALS

When selecting centrifugal pumps

NPSH-characteristic curve of a centrifugal pump

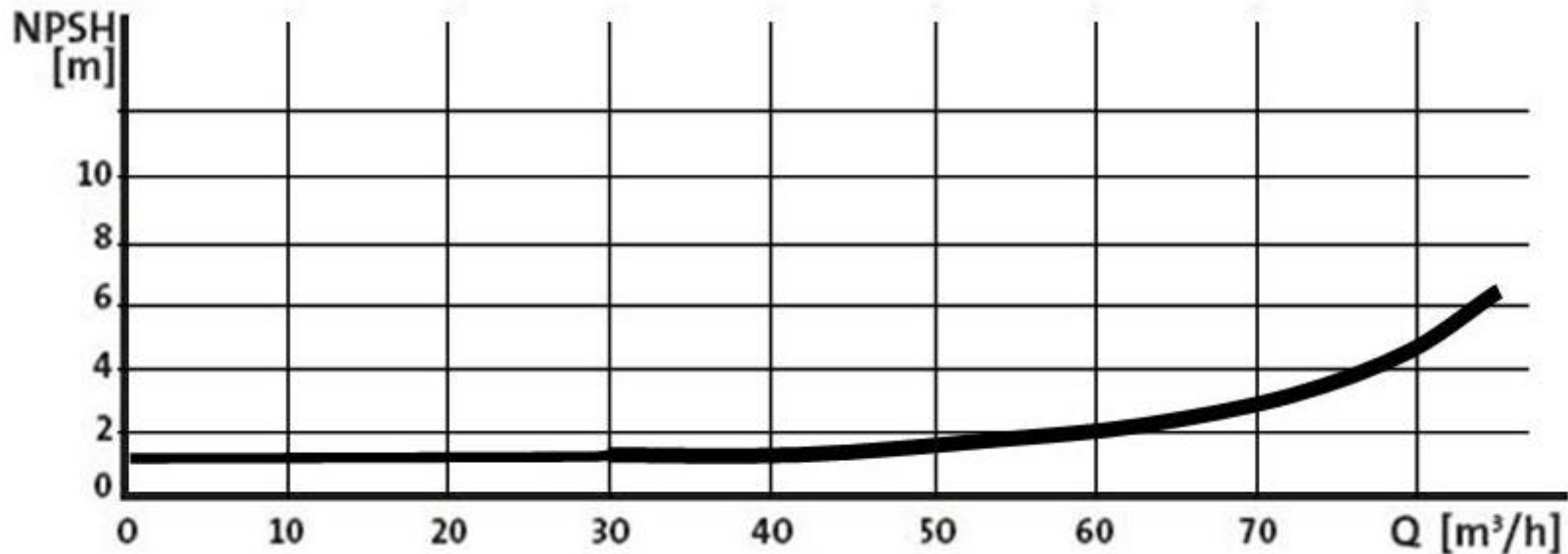

The NPSH-value (**NetPositiveSuctionHead**) is the minimum pressure required at the suction side of the pump in order for it to work. The **NPSH-value is measured in [m]** and rises with the increase in flow (Q).

The NPSH-value is calculated by tests for each pump according to the ISO 9906 standards and on a approved testbed.

Important: The **NPSHa** of a installation has to be larger than the **NPSHr** by the pump to allow it to pump and to eliminate cavitation etc...



BASIC PUMP FUNDAMENTALS

When selecting centrifugal pumps

Pump Head:

Pressure : Head (H) or Total Dynamic Head (TDH)

- When calculating Total Head the Suction Head should be listed separately to allow correct evaluation of the suction conditions
- Total Head (H) is made up of total Discharge Head (H_d) minus the Suction Head ($+H_s$) or plus the Suction Lift ($-H_s$)

$$H = H_d +/- H_s$$

Calculating NPSHa for suction lift

For a suction lift, where the supply level is below the pump centreline, the **NPSHa** can be calculated using the following equation:

$$NPSHa = h_a - h_v - h_s - h_{fs}$$

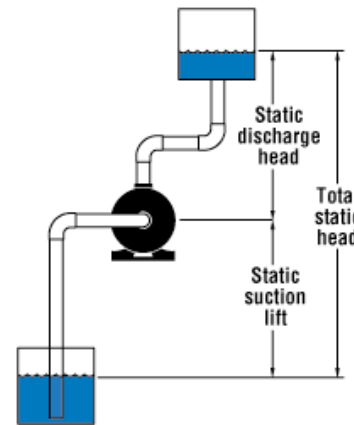



BASIC PUMP FUNDAMENTALS

When selecting centrifugal pumps

NPSH:

Where:

ha = the pressure on the surface of the supply vessel (m)

hv = velocity head or vapour pressure of the liquid at the operating temperature

hs = the suction lift or suction head to the pump centreline or impeller eye

hfs = all suction line losses

For a flooded suction

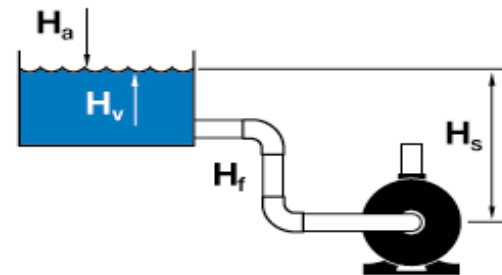

$$\text{NPSHa} = h_a - h_v + h_s - h_{fs}$$



BASIC PUMP FUNDAMENTALS

When selecting centrifugal pumps

Velocity Head (H_v)

Velocity head of a liquid moving with a certain velocity is the equivalent static head through which it would have to fall in order to attain that velocity. It also is the amount of head generated when fluid velocity drops to zero.

$$\text{Velocity Head (H}_v\text{)} = V^2 / 2g$$

V = Velocity of fluid (m/sec)

g = Acceleration due to gravity (9.81 m/sec²)



BASIC PUMP FUNDAMENTALS

When selecting centrifugal pumps

Velocity Head (Hv)

Velocity may be calculated for a given flow in a known diameter pipe by employing the formula below:

$$V = 1273 Q / d^2$$

Where:

Q = Quantity in l/s

d = Pipe diameter in mm

V = Fluid velocity in m/sec



BASIC PUMP FUNDAMENTALS

When selecting centrifugal pumps

Velocity Head (Hv)

For example we can now calculate the velocity head (Hv) in a 250mm diameter pipe in which there is a flow of 100 l/s

Calculate the velocity using

$$V = 1273 Q / d^2$$

$$V = 1273 \times 100 / 250^2$$

$$V = 2.04 \text{ m/sec}$$

Velocity Head

$$H_v = V^2 / 2g$$

$$H_v = 2.04^2 / 2 \times 9.81$$

$$H_v = 0.212 \text{ meters of fluid}$$

BASIC PUMP FUNDAMENTALS

When selecting centrifugal pumps

Suction Lift & Suction Head

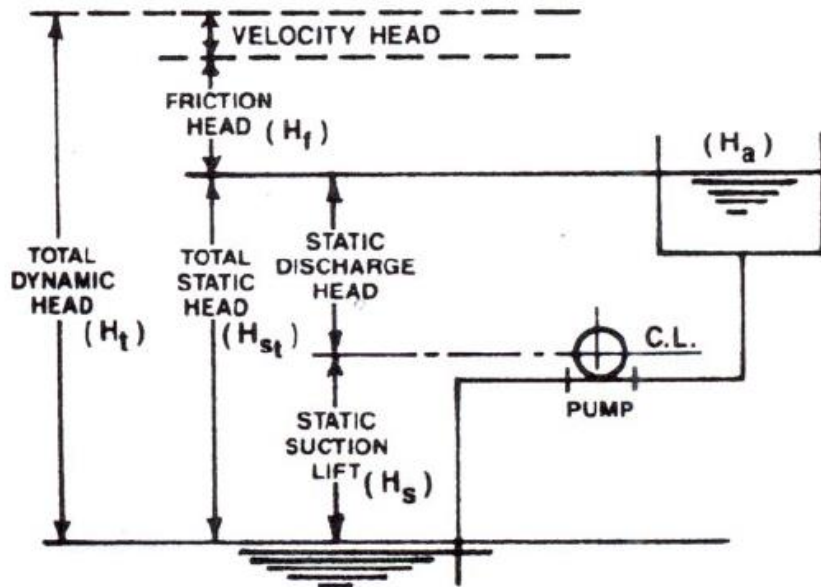

Fig. 1.3.1—Suction lift.

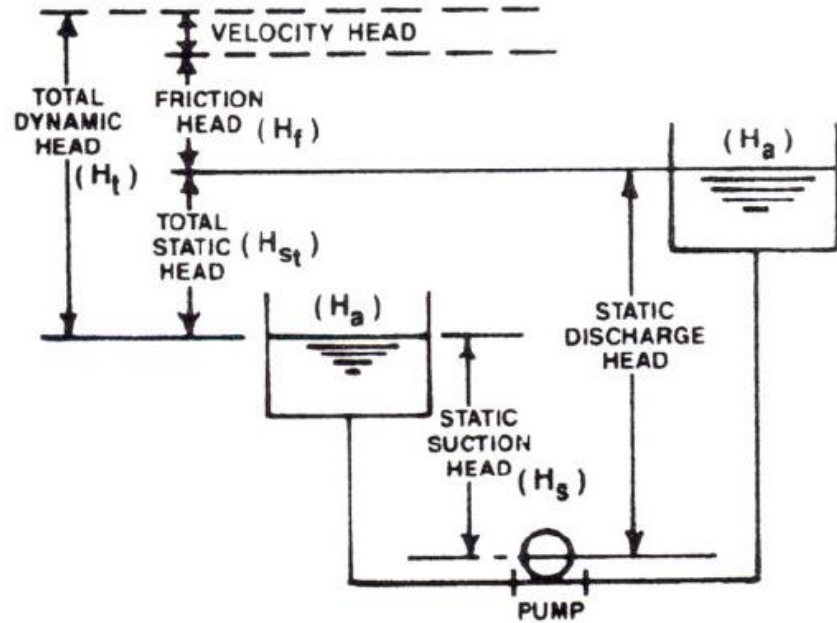

Fig. 1.3.2—Suction head.



BASIC PUMP FUNDAMENTALS

When selecting centrifugal pumps

Some tips to Keep in Mind:

The suction design of any pump system is key to a trouble free pumping operation

- Restricting the inlet port size and the inlet pipe ID will cause cavitation and damage the pump
- Rule of thumb is to have the suction pipes at least one size larger than the pump suction inlet
- Rule of thumb is to have a suction pipe velocity lower than 1.2 m/sec
- It is best to have a straight run of pipe leading into the pump inlet with an eccentric reducer
- The **NPSHa** must always be greater than **NPSHr** by the pump
- Use long radius bends on suction pipes
- Have suction slightly sloping upwards towards the pump suction nozzle
- Make sure there is no pipe stress on the pump nozzles after installation



BASIC PUMP FUNDAMENTALS

When selecting centrifugal pumps

Typical calculation of pump duty:

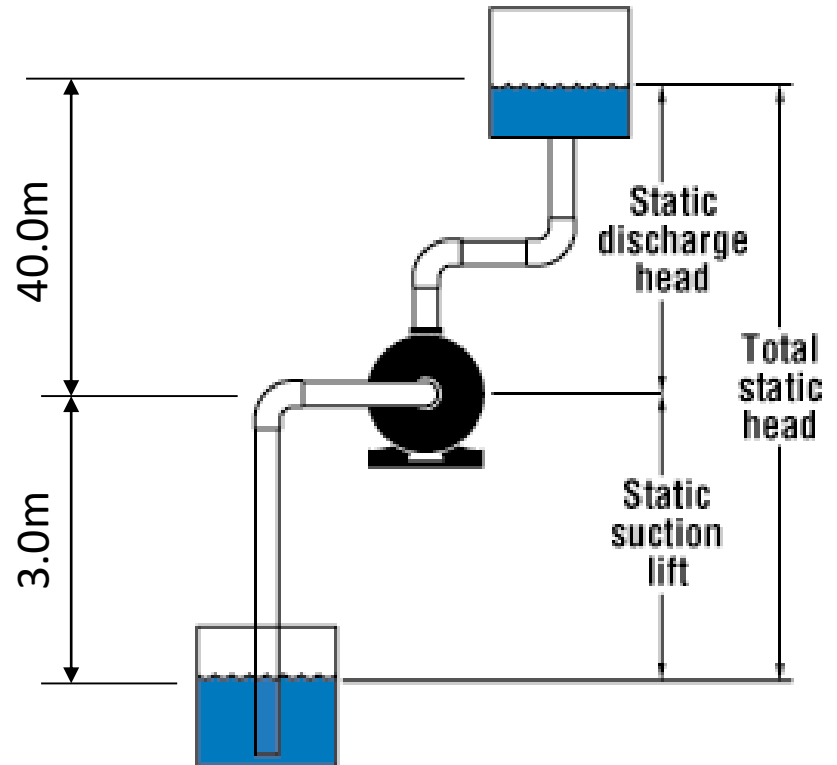



BASIC PUMP FUNDAMENTALS

When selecting centrifugal pumps

Calculation of pump duty:

Suction Lift	= 3.0m
Assumed friction losses	= 2.0m
Total suction head	= 5.0m
Discharge Static	= 40.0m
Assume friction losses	= 12.5m
Pressure required at discharge	= 17.5m
Total discharge head	= 70.0m
Total dynamic head = Hs + Hd	= 75.0m

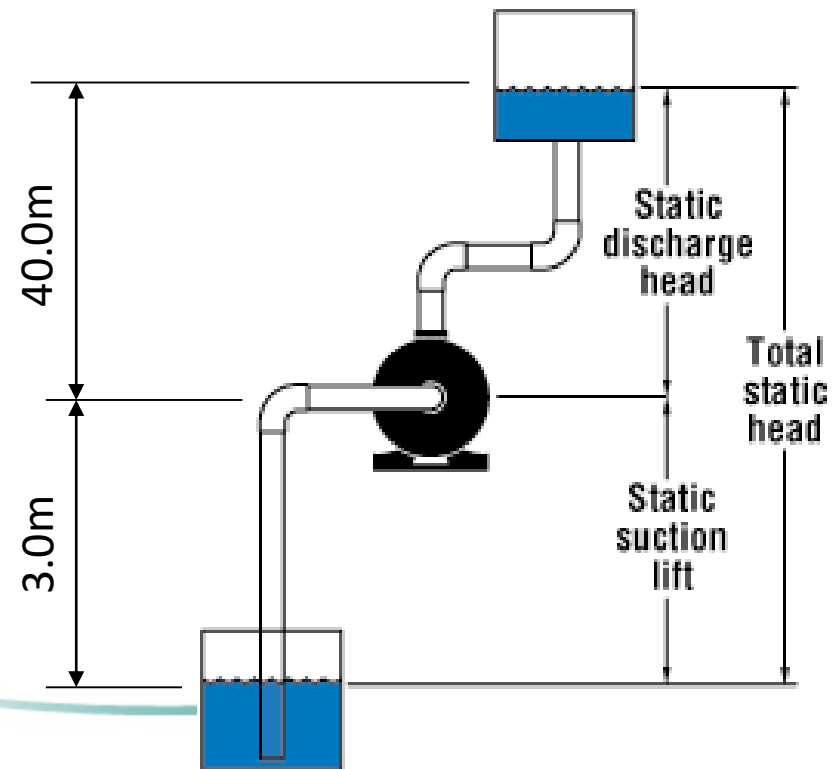



BASIC PUMP FUNDAMENTALS

When selecting centrifugal pumps

Selection of suitable Pump:

- We can now make a manual selection using our pump performance catalogue or we can use our computer aided selection program.



BASIC PUMP FUNDAMENTALS

When selecting centrifugal pumps

Computer Aided Pump Selection:

Many pump manufacturers provide computer programs to assist in pump selection.

KSB have developed a program called **Easy Select** and it is available on our website. This program will select the most suitable pumps for your particular application.

https://www.ksb.com/ksb-au/?gclid=EAlaIQobChMIgv76hZnS2wIVEBSPCh1vigAfEAAAYASAAEgLA1_D_BwE